

FEATURES & SPECIFICATIONS

- Rising stem, Outside Screw & Yoke (OS&Y)
- Stainless steel stem
- Valve conforms to AWWA C515 / BS5163
- Fusion bonded epoxy coated interior and exterior RAL3002
- Flange drilled to ANSI B16.1 Class 125 / ANSI B16.5 Class 150 / EN1092-2 PN16 / BS10 Table D / Table E
- Grooved ends to suit ANSI / AWWA and BS Pipe size
- Working pressure : 365psi
- Working temperature : -10°C ... 120°C

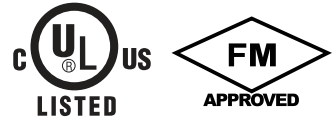

MATERIALS LIST

Name	Material
Body	Ductile Iron ASTM A536 65-45-12
Wedge	Ductile Iron ASTM A536 65-45-12 + EPDM
Wedge Nut	Bronze ASTM B62
Stem	Stainless Steel AISI 304
Bonnet	Ductile Iron ASTM A536 65-45-12
Gasket	EPDM
Packing	Graphite
Stem Nut	Bronze ASTM B62
Handwheel	Ductile Iron ASTM A536 65-45-12

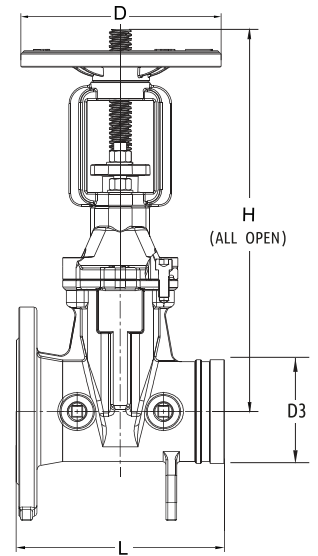

DIMENSIONS (inch/mm)

Size	2"/50	2.5"/65	3"/80	4"/100	5"/125	6"/150	8"/200	10"/250	12"/300						
L	7.00/178	7.50/191	8.00/203	9.00/229	10.00/254	10.50/267	11.50/292	13.00/330	14.00/356						
H	16.1/409	16.1/409	18.19/462	20.55/522	28.15/715	28.15/715	35.94/913	44.01/1118	51.18/1300						
D	6.3/160	6.3/160	8.66/220	8.66/220	11.02/280	11.02/280	14.56/370	16.53/420	16.53/420						
D3	2.37/60.3	2.87/73	2.99/76.1	2.37/88.9	4.5/114.3	5.56/141.3	5.5/139.7	6.63/168.3	6.5/165.1	8.63/219.1	8.51/216.3	10.75/273.1	10.52/267.4	12.75/323.9	12.53/318.5

NET WEIGHT (kg) & CRATE QTY (pcs)

Size	2"/50	2.5"/65	3"/80	4"/100	5"/125	6"/150	8"/200	10"/250	12"/300
N.W.	17.64	18.91	22.13	27.16	40.30	46.90	72.00	111.00	167.00
Crate Qty	25	25	16	16	9	9	6	4	2