

FEATURES & SPECIFICATIONS

- Non-rising stem
- Stainless steel stem
- Valve conforms to AWWA C515 / BS5163
- Fusion bonded epoxy coated interior and exterior RAL3002
- Flange drilled to ANSI B16.1 Class 125 / ANSI B16.5 Class 150 / EN1092-2 PN16 / BS10 Table D / Table E
- Mechanical joint ends to AWWA C111 / A21.11
- Working pressure : 365psi
- Working temperature : -10°C ... 120°C
- All valves provided with 2" (50mm) operating nut

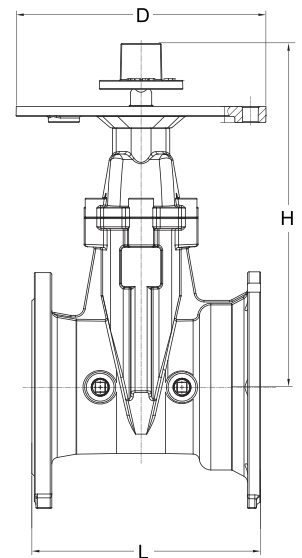
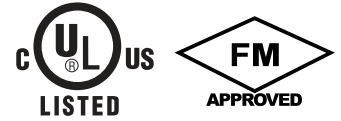

MATERIALS LIST

Name	Material
Body	Ductile Iron ASTM A536 65-45-12
Wedge Disc	Ductile Iron ASTM A536 65-45-12 + EPDM
Disc Nut	Bronze ASTM B62
Stem	Stainless Steel AISI 304/402
Gasket	EPDM
Bonnet	Ductile Iron ASTM A536 65-45-12
Thrust Collar	Bronze ASTM B62
Gland	Ductile Iron ASTM A536 65-45-12
Wrench Nut	Ductile Iron ASTM A536 65-45-12
Post Plate	Ductile Iron ASTM A536 65-45-12

DIMENSIONS (inch/mm)

Size	3"/80	4"/100	6"/150	8"/200	10"/250	12"/300
L	8.74/222.0	9.51/242	11.00/280	12.01/305	13.88/353	14.45/367.0
H	11.54/293	12.83/326	16.54/420	19.92/506	24.02/610	27.99/711
D	12.01/305	12.01/305	12.01/305	12.01/305	12.01/305	12.01/305

NET WEIGHT (kg) & CRATE QTY (pcs)

Size	3"/80	4"/100	6"/150	8"/200	10"/250	12"/300
N.W.	21.29	25.75	41.42	70.60	105.48	157.50
Crate Qty	9	9	9	9	4	2