

FEATURES & SPECIFICATIONS

- Non-rising stem
- Stainless steel stem
- Valve conforms to AWWA C515 / BS5163
- Fusion bonded epoxy coated interior and exterior RAL3002
- Flange drilled to ANSI B16.1 Class 125 / ANSI B16.5 Class 150 / EN1092-2 PN16 / BS10 Table D / Table E
- Grooved ends to suit ANSI / AWWA and BS Pipe size
- Working pressure : 365psi
- Working temperature : -10°C ... 120°C
- All valves provided with 2" (50mm) operating nut

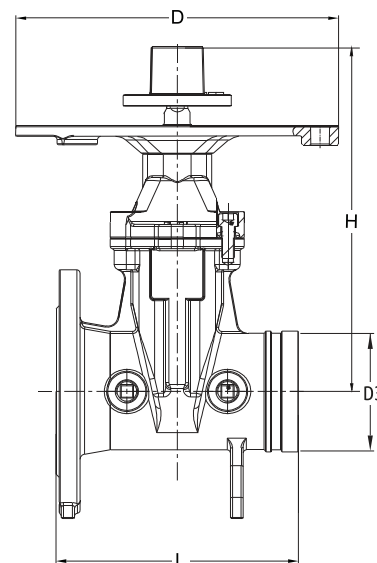
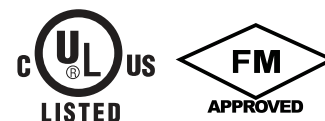

MATERIALS LIST

Name	Material
Body	Ductile Iron ASTM A536 65-45-12
Wedge Disc	Ductile Iron ASTM A536 65-45-12 + EPDM
Disc Nut	Bronze ASTM B62
Stem	Stainless Steel AISI 304
Gasket	EPDM
Bonnet	Ductile Iron ASTM A536 65-45-12
Thrust Collar	Bronze ASTM B62
Gland	Ductile Iron ASTM A536 65-45-12
Wrench Nut	Ductile Iron ASTM A536 65-45-12
Post Plate	Ductile Iron ASTM A536 65-45-12

DIMENSIONS (inch/mm)

Size	2"/50	2.5"/65	3"/80	4"/100	5"/125	6"/150	8"/200	10"/250	12"/300						
L	7.00/178	7.5/191	8.00/203	9.00/229	10.00/254	10.50/267	11.50/292	13.00/330	14.00/356						
H	10.35/263	10.35/263	11.53/293	12.83/326	16.53/420	16.53/420	19.92/506	24.01/610	27.99/711						
D	12.01/305	12.01/305	12.01/305	12.01/305	12.01/305	12.01/305	12.01/305	12.01/305	12.01/305						
D3	2.37/60.3	2.87/73	2.99/76.1	2.37/88.9	4.5/114.3	5.56/141.3	5.5/139.7	6.63/168.3	6.5/165.1	8.63/219.1	8.51/216.3	10.75/273.1	10.52/267.4	12.75/323.9	12.53/318.5

NET WEIGHT (kg) & CRATE QTY (pcs)

Size	2"/50	2.5"/65	3"/80	4"/100	5"/125	6"/150	8"/200	10"/250	12"/300
N.W.	24.00	25.30	27.50	35.00	42.00	50.00	83.00	123.50	175.50
Crate Qty	9	9	9	9	9	9	9	4	2