

FEATURES & SPECIFICATIONS

- Rising stem, Outside Screw & Yoke (OS&Y)
- Stainless steel stem
- Valve conforms to AWWA C515 / BS5163
- Fusion bonded epoxy coated interior and exterior RAL3002
- Flange drilled to ANSI B16.1 Class 125 / ANSI B16.5 Class 150 / EN1092-2 PN16 / BS10 Table D / Table E
- Mechanical joint ends to AWWA C153 / A21.53
- Working pressure : 300psi
- Working temperature : -10°C ... 120°C

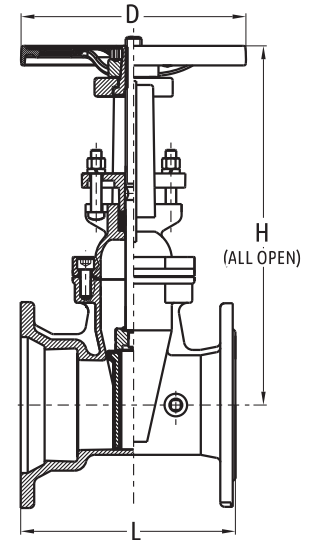
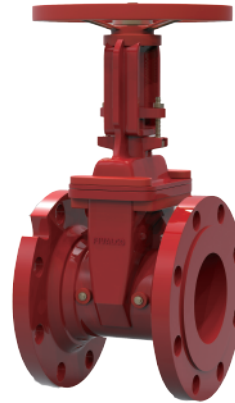

MATERIALS LIST

Name	Material
Body	Ductile Iron ASTM A536 65-45-12
Wedge	Ductile Iron ASTM A536 65-45-12 + EPDM
Wedge Nut	Stainless Steel AISI 304
Stem	Stainless Steel AISI 304/420
Bonnet	Ductile Iron ASTM A536 65-45-12
Gasket	EPDM
Packing	Graphite
Stem Nut	Bronze ASTM B62
Handwheel	Ductile Iron ASTM A536 65-45-12

DIMENSIONS (inch/mm)

Size	3"/80	4"/100	6"/150	8"/200	10"/250	12"/300
L	8.74/222	9.51/241.5	11/279.5	12.00/305	13.88/352.50	14.45/367
H	18.19/462	20.24/514	27.91/709	33.31/922	43.94/1116	51.18/1300
D	9.96/253	9.96/253	12.05/306	13.98/355	17.52/445	17.52/445

NET WEIGHT (kg) & CRATE QTY (pcs)

Size	3"/80	4"/100	6"/150	8"/200	10"/250	12"/300
N.W.	22.13	27.16	46.90	72.00	111.00	167.00
Crate Qty	16	16	9	6	4	2